

Wireless Module BP35C2
Hardware Specification

Revision 1.0.0

Revision record

Rev.	Rev. Date	Items	Remarks
1.0.0	2018/10/29	Issue	ROHM

Notice**● Precaution on using ROHM Products**

- 1) Our Products are designed and manufactured for application in ordinary electronic equipment (such as AV equipment, OA equipment, telecommunication equipment, home electronics appliances, amusement equipment, etc.). If you intend to use our Products in devices requiring extremely high reliability (such as medical equipment, transport equipment, traffic equipment, aircraft/spacecraft, nuclear power controllers, fuel controllers, car equipment including car accessories, safety devices, etc.) and whose malfunction or failure may cause loss of human life, bodily injury or serious damage to property (“Special Applications”), please consult with the ROHM sales representative in advance. Unless otherwise agreed in writing by ROHM in advance, ROHM shall not be in any way responsible or liable for any damages, expenses or losses incurred by you or third parties arising from the use of any ROHM’s Products for Specific Applications.
- 2) ROHM designs and manufactures its Products subject to strict quality control system. However, semiconductor products can fail or malfunction at a certain rate. Please be sure to implement, at your own responsibilities, adequate safety measures including but not limited to fail-safe design against the physical injury, damage to any property, which a failure or malfunction of our Products may cause. The following are examples of safety measures.
 - [a] Installation of protection circuits or other protective devices to improve system safety.
 - [b] Installation of redundant circuits to reduce the impact of single or multiple circuit failure.
- 3) Our Products are designed and manufactured for use under standard conditions and not under any special or extraordinary environments or conditions, as exemplified below. Accordingly, ROHM shall not be in any way responsible or liable for any damages, expenses or losses arising from the use of any ROHM’s Products under any special or extraordinary environments or conditions. If you intend to use our Products under any special or extraordinary environments or conditions (as exemplified below), your independent verification and confirmation of product performance, reliability, etc., prior to use, must be necessary:
 - [a] Use of our Products in any types of liquid, including water, oils, chemicals, and organic solvents
 - [b] Use of our Products outdoors or in places where the Products are exposed to direct sunlight or dust
 - [c] Use of our Products in places where the Products are exposed to sea winds or corrosive gases, including Cl₂, H₂S, NH₃, SO₂, and NO₂
 - [d] Use of our Products in places where the Products are exposed to static electricity or electromagnetic waves
 - [e] Use of our Products in proximity to heat-producing components, plastic cords, or other flammable items
 - [f] Sealing or coating our Products with resin or other coating materials
 - [g] Use of the Products in places subject to dew condensation
- 4) The Products are not subject to radiation-proof design.
- 5) Please verify and confirm characteristics of the final or mounted products in using the Products.
- 6) Confirm that operation temperature is within the specified range described in the product specification.
- 7) ROHM shall not be in any way responsible or liable for failure induced under deviant condition from what is defined in this document.
- 8) This Product may be subjected to radio wave interference from other equipment emitting radio waves.
- 9) This Product emits radio waves due to the specification. To use equipment emitting radio waves, certification under the Radio Act should be obtained by region in which the Product is used. For the standards for certification under the Radio Act to be obtained for the use of this Product, separately contact your ROHM representative.

Notice**● Precaution for Electrostatic**

This Product is electrostatic sensitive product, which may be damaged due to electrostatic discharge. Please take proper caution in your manufacturing process and storage so that voltage exceeding Products maximum rating will not be applied to Products. Please take special care under dry condition (e.g. Grounding of human body / equipment / solder iron, isolation from charged objects, setting of Ionizer, friction prevention and temperature / humidity control).

● Precaution for Storage / Transportation

- 1) Product performance may deteriorate if the Products are stored in the places where:
 - [a] The Products are exposed to sea winds or corrosive gases, including Cl₂, H₂S, NH₃, SO₂, and NO₂
 - [b] The temperature or humidity exceeds those recommended by ROHM
Temperature: 5 °C – 40 °C, Humidity: 40 %RH – 60 %RH
 - [c] The Products are exposed to direct sunshine or condensation
 - [d] The Products are exposed to high Electrostatic
- 2) ROHM shall assure the performance of this Product such as connector fitting performance for a period of one (1) year after the shipment from ROHM; provided, however, that this shall be limited to the cases where the foregoing conditions for storage are observed.
- 3) Store / transport cartons in the correct direction, which is indicated on a carton as a symbol. Otherwise bent leads, causing the case to deform or come off, or other troubles may occur due to excessive stress applied when dropping of a carton.

● Precaution for product label

QR code printed on ROHM product label is for ROHM's internal use only, and please do not use at customer site.

● Precaution for disposition

When disposing Products please dispose them properly using an authorized industry waste company.

● Precautions Regarding Intellectual Property Rights

- 1) All information and data including but not limited to application example contained in this document is for reference only. ROHM does not warrant that foregoing information or data will not infringe any intellectual property rights or any other rights of any third party regarding such information or data.
- 2) ROHM shall not have any obligations where the claims, actions or demands arising from the combination of the Products with other articles such as components, circuits, systems or external equipment (including software)
- 3) No license, expressly or implied, is granted hereby under any intellectual property rights or other rights of ROHM or any third parties with respect to the Products or the information contained in this document. Provided, however, that ROHM will not assert its intellectual property rights or other rights against you or your customers to the extent necessary to manufacture or sell products containing the Products, subject to the terms and conditions herein.

Notice**• Other Matters**

- 1) This document may not be reprinted or reproduced, in whole or in part, without prior written consent of ROHM.
- 2) The Products may not be disassembled, converted, modified, reproduced or otherwise changed without prior written consent of ROHM.
- 3) In no event shall you use in any way whatsoever the Products and the related technical information contained in the Products or this document for any military purposes, including but not limited to, the development of mass-destruction weapons.
- 4) The proper names of companies or products described in this document are trademarks of registered trademarks of ROHM, its affiliated companies or third parties.

1. Structure

Assembly using a printed circuit board

2. Product Name

Hybrid IC

3. Model Name

BP35C2

4. Application

Telecommunication equipment

5. Function

Specified low power radio module (920 MHz band) (USB dongle type)

6. Absolute Maximum Ratings

No.	Parameter	Symbol	Rating	Unit	Condition
1	Supply voltage (USB)	VDD	+4.5 to +5.5	V	DC
2	Operating temperature range	Topr	-20 to +50	°C	
3	Storage temperature range	Tstg	-20 to +70	°C	

(Note) The absolute maximum ratings represent values that shall not be exceeded for even an instant on all operating or testing conditions.

Design systems with a margin for the ratings listed above.

7. Recommended Operating Conditions

No.	Parameter	Symbol	Specification			Unit	Condition
			Min.	Typ.	Max.		
1	Supply voltage (USB)	VDD	4.5	5.0	5.5	V	
2	Operating temperature range	Ta	-20	+25	+50	°C	

8. Major Performance

Parameter	Description
Radio standards	Compliant with ARIB STD-T108
Radio frequency	920 MHz band
Modulation method	Binary GFSK
Data rate	100 kbps
Transmission power	20 mW output
Receiving sensitivity	-103 dBm (Typ.) (100 kbps, BER<0.1 %)
Frequency deviation	±20 ppm or less
Current consumption (VDD=5.0 V) (Data rate=100 kbps)	48 mA (Typ.) [Transmission: 20 mW output] 30 mA (Typ.) [Reception] 6 mA (Typ.) [Sleep state]
Host interface	USB (USB 2.0)

9. Block Diagram

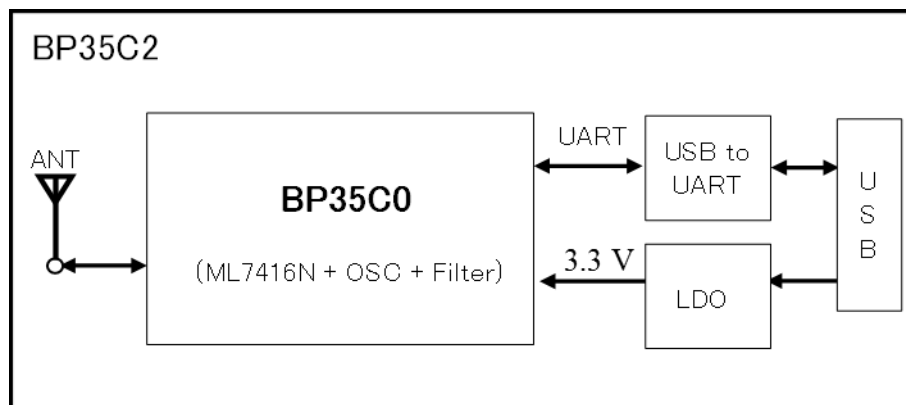

Fig. 1. Block Diagram

10. Electrical Characteristics

Input current characteristics

(Ta=25 °C, VDD=5.0 V)

No.	Parameter	Condition	Specification			Unit
			Min.	Typ.	Max.	
1	Current consumption (Data rate: 100 kbps)	Transmission state (set to 20 mW)	-	48	57	mA
2		Reception state	-	30	39	mA
3		Sleep state* (Held by register)* ¹	-	6	-	mA

Measurement was made with the terminal of 50-ohm measuring instrument connected with the antenna connector terminal of the module using RF cable.

Be noted that the parameter marked with “*” represents a design guaranteed value.

*1: Shifted to sleep mode when the “SKDSLEEP” command is executed.

RF characteristics (internal BP35C0’s specifications)

Measurement conditions: Ta=25 °C and VDD_C0=3.3 V (Input power supply voltage of BP35C0)

Data rate: 100 kbps

Modulation method: Binary GFSK

Channel spacing: 400 kHz

Measurement made at the antenna connector terminal of the module.

Transmission characteristics

(Ta=25 °C, VDD_C0=3.3 V)

No.	Parameter	Condition	Specification			Unit
			Min.	Typ.	Max.	
1	Transmission output power	20 mW mode	12.2	13.0	13.6	dBm
2	Occupied bandwidth	n=2	-	175	400	kHz
3	Adjacent channel leakage power [ACPR]	20 mW mode±1 channel Bandwidth: 200 kHz	-	-36	-15	dBm
4	Frequency shift [Fdev]*	-	35	50	65	kHz

Be noted that the parameter marked with “*” represents a design guaranteed value.

Transmission characteristics (continued)

(Ta=25 °C, VDD_C0=3.3 V)

No.	Parameter	Condition	Specification			Unit
			Min.	Typ.	Max.	
5	Spurious emission levels for transmission (in 20 mW mode)	100 kHz bandwidth below 710 MHz	-	-74	-36	dBm
6		1 MHz bandwidth between 710 MHz and 900 MHz		-68	-55	dBm
7		100 kHz bandwidth between 900 MHz and 915 MHz	-	-76	-55	dBm
8		100 kHz bandwidth between 915 MHz and 930 MHz (except levels detuned by 400 kHz or less from the center of radio channels (n=2); provided that levels ranging from 920.5 MHz to 922.3 MHz and detuned by 300 kHz or less shall be excluded)	-	-42	-36	dBm
9		100 kHz bandwidth between 930 MHz and 1 GHz	-	-69	-55	dBm
10		1 MHz bandwidth between 1 GHz and 1.215 GHz	-	-70	-45	dBm
11		1 MHz bandwidth over 1.215 GHz (over second harmonic)	-	-48	-30	dBm

Reception characteristics

(Ta=25 °C, VDD_C0=3.3 V)

No.	Parameter	Condition	Specification			Unit
			Min.	Typ.	Max.	
12	Minimum receiving sensitivity	* BER<0.1 %, 100 kbps mode	-	-103	-95	dBm
		* PER<1.0 % 100 kbps mode, 100 byte data	-	-99	-91	
13	Maximum receiving input level*	100 kbps mode	0	-	-	dBm
14	Adjacent interference of C/I performance in a reception circuit*	100 kbps mode	20	41	-	dB
15	Next-adjacent interference of C/I performance in a reception circuit*	100 kbps mode	30	48	-	dB
16	Minimum power detection (ED value) level*	-	-	-	-95	dBm
17	Power detection range*	Dynamic range	60	70	-	dB
18	Power detection accuracy*	-	-6	-	+6	dB

Be noted that the parameter marked with “*” represents a design guaranteed value.

Reception characteristics (continued)

(Ta=25 °C, VDD_C0=3.3 V)

No.	Parameter	Condition	Specification			Unit
			Min.	Typ.	Max.	
19	Subsidiary emission levels	100 kHz bandwidth below 710 MHz*	-	-76	-54	dBm
20		1 MHz bandwidth between 710 MHz and 900 MHz*	-	-71	-55	dBm
21		100 kHz bandwidth between 900 MHz and 915 MHz*	-	-83	-55	dBm
22		100 kHz bandwidth between 915 MHz and 930 MHz*	-	-83	-54	dBm
23		100 kHz bandwidth between 930 MHz and 1 GHz*	-	-81	-55	dBm
24		1 MHz bandwidth over 1 GHz *	-	-60	-47	dBm

Be noted that the parameter marked with “*” represents a design guaranteed value.

11. Interface Characteristics

USB specification

USB 2.0 standard

UART specification (internal exchanging USB to UART)

Parameter	Specification
Baud rate	115,200 bps
Data	8 bits
Parity	Not provided
Stop bit	1 bit
HW flow control	Disabled (Default)(*3)

(*3) UART flow control is disabled (defaulted) when the “WUART 00” is executed.

UART flow control is enabled when the “WUART 80” command is executed.

Every time this command is executed, the setting of the flow control is written and saved to the internal flash memory. The setting remains saved in the memory even if the power supply is turned ON again. There is a limit to the number of times to writing data to the flash memory (not more than 10,000 times). This limit to the number of times should be noted. It is recommended to execute the command just once to make setting of the UART flow control.

You should verify and determine whether to disable or enable the HW flow control.

Startup time

Insert “WAIT” period of three seconds or more before the first command is issued after turning ON the power supply or resetting.

12. Channel Setting

n=2 (Bandwidth: 400 kHz, Data rate: 100 kbps)

Unit Channel Number	Center Frequency (MHz)	Unit Channel Number	Center Frequency (MHz)
		43, 44	924.5
		44, 45	924.7
		45, 46	924.9
		46, 47	925.1
		47, 48	925.3
		48, 49	925.5
		49, 50	925.7
		50, 51	925.9
33, 34	922.5	51, 52	926.1
34, 35	922.7	52, 53	926.3
35, 36	922.9	53, 54	926.5
36, 37	923.1	54, 55	926.7
37, 38	923.3	55, 56	926.9
38, 39	923.5	56, 57	927.1
39, 40	923.7	57, 58	927.3
40, 41	923.9	58, 59	927.5
41, 42	924.1	59, 60	927.7
42, 43	924.3	60, 61	927.9

This Product is available for use in the range of 33, 34CH (922.5 MHz) to 60, 61CH (927.9 MHz).

13. Setting of Communication Time Limit and Carrier Sensing Time

This Product has acquired the Technical Regulations Conformity Certification with the settings listed in the table below. The Products is not allowed to be used with any setting outside the setting range listed below.

Unit Channel Number	Data rate setting (Number of channels to use at a time)	Carrier sensing time	Transmission time limit	Pause time	Total of transmission time per hour
33-61	100 kbps (n=2)	148 μ s or more (Sensing at all times)	200 ms or less per transmission	2 ms or more	360 s or less

14. List of Pins

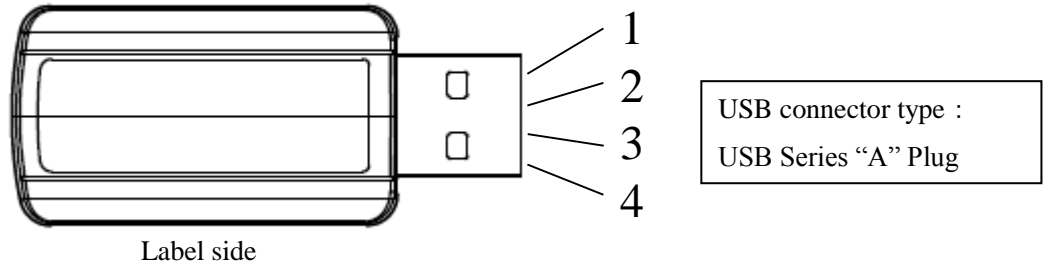

Pin No.	Pin Name	I/O	Function
1	VDD	-	Power supply pin
2	-Data(D -)	I/O	USB data input/output
3	+Data(D +)	I/O	USB data input/output
4	GND	-	Ground pin

*I/O definition - I: Digital input pin, O: Digital output pin

15. Outline Dimensions

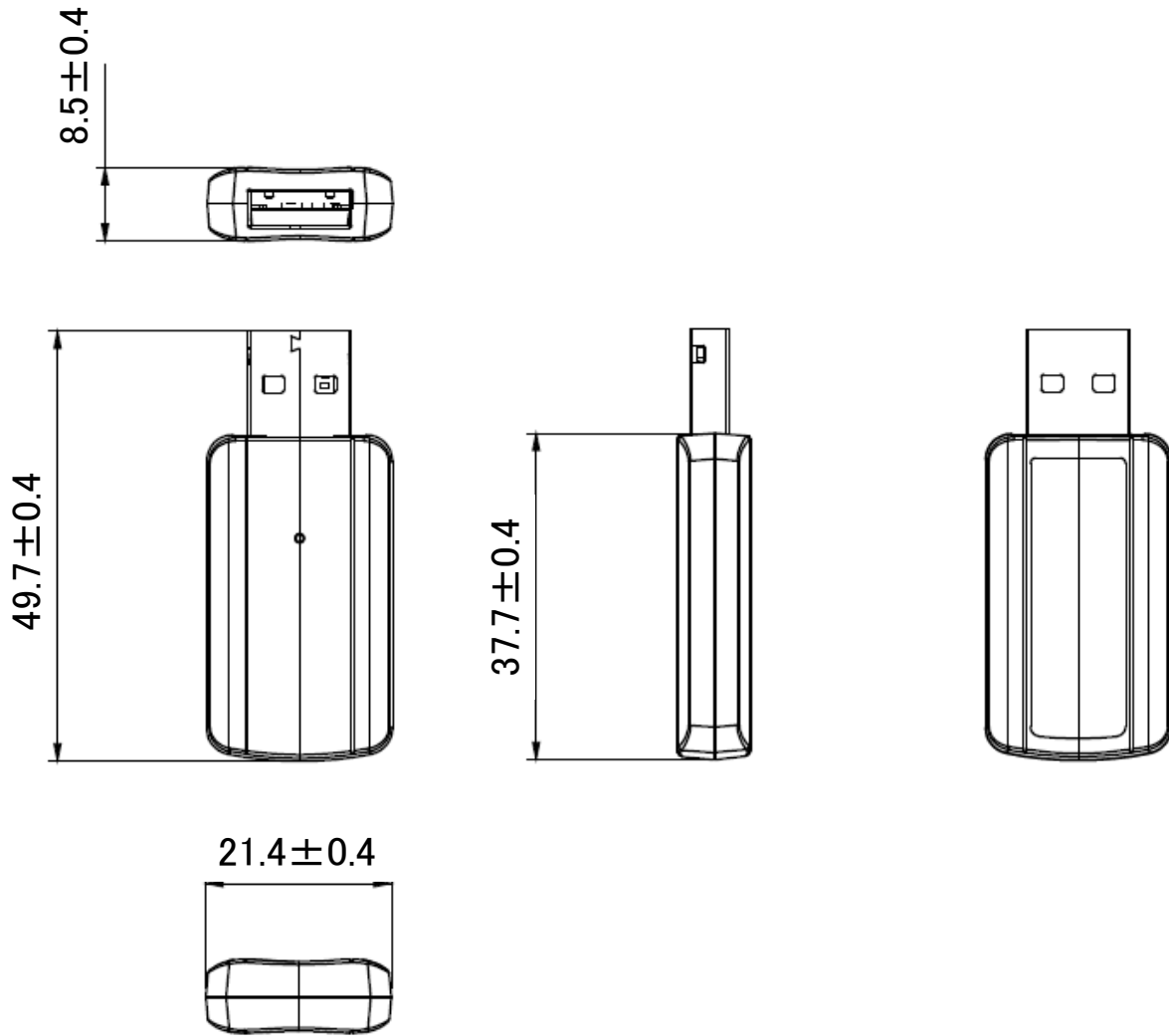

UNIT: mm

Fig. 2. Outline Dimensions Diagram

*Any defects in the appearance other than scratches and dents harmful to the practical use of this Product are overlooked.

16. Product Marking and Labeling Specification

The following items are indicated on the product.

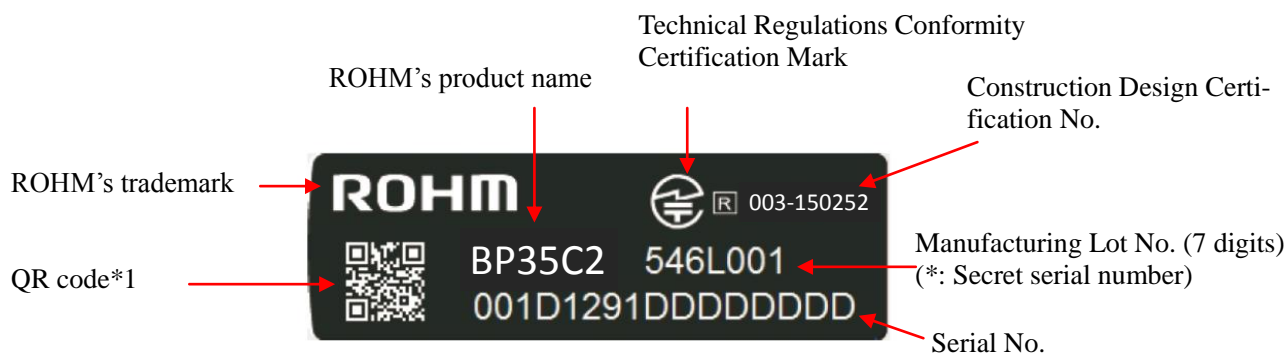

Fig. 3. Marking Specification

*1 QR code has a product serial number as information.
The design of marking is subject to change without prior notice.

Marking items

ROHM

: ROHM's trademark

BP35C2

: ROHM's product name

546*▲▲▲

: Manufacturing Lot No. (3 digits)

(Example) 546*▲▲▲▲ → 2015_46th week*▲▲▲ Manufactured

(*: Secret serial number)

(▲▲▲: Secret serial number)

Ⓜ 003-150252

: Construction Design Certification No.



: Technical Regulations Conformity Certification Mark

Labeling items

001D12*****

: Individual address

001D12 (OUI (Vendor ID): ROHM)

17. Product Mass

8.0 g

18. Precautions for Use

- 1) There are cases where lot numbers are different in the same middle carton.
- 2) There are cases where serial numbers are not in sequence in the same middle carton.
- 3) About soldering parts of mounting on this Product, presence of soldering fillet does not be asked.
- 4) With respect to a label affixed to this Product, defects other than “peeling”, “sticking-out”, and “extreme defect in character recognition” are overlooked.
- 5) BP35C2 may cause the connector or case to come off due to its structure when it receives excessive vibration or impact. To use this Product in places where the Product can receive vibration or impact, conduct thorough evaluation in advance.
- 6) Use this Product without cleaning residue of flux.
- 7) About wireless communication
 1. Wireless communication may be unstable due to radio wave environment and communication environment, does not guarantee 100 % data transfer, ROHM shall not be in any way responsible or liable for data missing.
 2. UDP does not provide for the arrival of consecutive packets and data arrival is not guaranteed.
 3. Please fully verify with customers before installing this Product in customer's set and doing full-scale operation.
 4. ROHM shall not be in any way responsible or liable for any damage or malfunction caused by data interception, loss, theft, leakage to a third party.
 5. For customers who are verifying points relating to specific communication, please introduce SK Catcher, a product of Skyley Networks Inc. As a rule, support of the contents related to communication is prerequisite to notify about SK Catcher log and SK Catcher product ID number.

19. Precautions as Radio Equipment

BP35C2 has acquired the “Construction design certification” (Article 38-24 (1) of the Radio Act) for “Radio Equipment: Specified low power equipment of less than 13 GHz prescribed in Article 2-1 (8) Type of Specified Radio Equipment.” with built-in BP35C0.

Consequently, BP35C2 is available for use as radio equipment only in Japan without making an application for radio station license.

- Construction Design Certification Number: 003-150252

To safely use BP35C2 as radio equipment, be sure to observe the following.

- 1) The marking of this Product indicates that it has acquired the “Technical Regulations Conformity Certification”. Do not erase the marking or affix any label on the marking.
- 2) Never disassembly or modify this Product. Doing so may be subject to punishment under the Radio Act.

20. Firmware

20.1 Firmware licensing

With respect to the built-in firmware of this Product, agree to the following licensing prior to use.

- 1) This software is firmware dedicated to BP35C2. Do not use the firmware for any product other than BP35C2.
- 2) ROHM has the copyright (including the rights prescribed in Articles 27 and 28 of the Copyright Act) and any and all other intellectual property rights of this Software. This Software shall be licensed only for the use of BP35C2.
- 3) Do not assign, transfer, sub-license, or lend this Software to any third parties.
- 4) Reverse engineering, decompilation, disassembly, reproduction, and change of this Software are prohibited.
- 5) ROHM shall not guarantee any and all operations performed by using this Software.
- 6) Since this software will be updated, be sure to implement the update function of this software on the customer's set main unit. Please inquire about the update method separately.
- 7) In the event of a defect or the like to be attributed to ROHM under normal use for the Software during the first six (6) months from (1) Initial delivery date of BP35C2 or (2) Date of this specification change, customer must notify ROHM immediately.
- 8) Please note that ROHM does not pay any costs (including but not limited to outsourcing expenses, repair expenses, product collection expenses, alternative procurement costs, etc.) paid by customers from third parties due to defects etc. without prior consent of ROHM.
- 9) In any case, the amount borne by ROHM due to defects etc. of the software shall be no more than the last six (6) months of the total sales value of BP35C2 from ROHM to the customer.
- 10) If the provisions of Article 20.1 of this specification, the provisions of the basic contract to be concluded, any contracts and memoranda, incidental thereto, and other specifications of this specification between customer and ROHM contradict or conflict, the provisions of this section shall prevail.

20.2 Firmware version

- 1) The version of firmware written to this Product is the latest version at the time when it is manufactured.
- 2) Firmware may not be the latest version depending on the shipment timing.
- 3) The version of firmware is subject to change without prior notice. ROHM shall not be in any way responsible or liable for damages of customers caused by such changes.
- 4) The version of firmware written to this Product cannot be distinguished by the appearance of the Product.
- 5) The same firmware is written to Products contained in the same package.

20.3 Method for checking firmware version

Firmware version can be checked using the following commands.

-Use "SKVER" command to check stack version

-Use "SKAPPVER" command to check application version

For details, refer to information in "BP35C2_command reference."

20.4 Number of rewritable firmware

The maximum number of times that the firmware of this Product can be rewritten is 100 times. If you rewrite the firmware beyond this number, ROHM will not guarantee the operation of this Product.